

GENERAL SAFETY

Contact Event Hire for information and advice on the suitability and safety of this type of equipment.

There is a risk of injury if you do not follow the instructions printed in this guide.

This equipment should only be used by a competent adult who has read and understood the instructions in this leaflet.

Anyone with a temporary or permanent disability should seek expert advice before using the equipment.

Keep all children, animals and bystanders away from the set up area. Ensure the floor is free from trip hazards and non-slip.

Never use the equipment if you are ill, tired or under the influence of alcohol or drugs.

Never operate electrical switches with wet hands.

Always switch off and unplug the equipment from the power supply before moving or cleaning.

Check the equipment before use, if it shows signs of damage request a replacement.

ELECTRICAL SAFETY

The equipment is designed to plug directly into a standard 240volt, 13 amp socket. Make sure the equipment and power socket are switched off before plugging into the power supply.

If the equipment fails to operate or the power cable or plug become damaged, contact Event Hire, do not try to repair it yourself.

Keep the power cable out of harm's way. Extension leads should be unwound fully, never run them through water, over sharp objects or where they may be a trip hazard.

Use a suitable RCD (Residual Current Operated Device) to reduce the risk of electric shock.

OPERATING GUIDE

- For Indoor Use Only. The unit requires 240v & wifi connection
- The unit comes complete in a single flight case on castors ready for immediate use. At least 2 people should be used to manoeuvre the unit into position.
- Position the unit where it is to be used, well away from any heat source and with sufficient clearance all round for air circulation.
- Ensure that it is on a level surface and once in position, lock the castors to ensure the unit will not move unexpectedly.
- Once in position, remove the sides of the flight case and the TV console is made available for use.
- Connect the power lead to a standard 240v electrical socket.

OPERATING GUIDE cont'd

Once wifi connection has been established, the unit will give access to:

- Samsung 43" Smart Ultra LED TV
- Digital TV reception aerial
- Playstation 4 or Xbox One
- Apple TV HD
- Bluetooth enabled music streaming
- Yamaha MUSICCAST BAR 400 black soundbar with sub-woofer

Entertainment Hub Control Instructions



TV Set Remote

Red Button to turn TV on.

Press Source Button to switch between:

TV
APPLE TV
PLAYSTATION 4

Use up and down arrows then "Select Option" Button to select desired function.



Sound Bar Remote

Switch Sound Bar On

Select "TV" if using TV, PlayStation or Apple TV

Select "Bluetooth" if steaming music through soundbar from Smartphone, Tablet or any external device

Bluetooth Audio Streaming

To connect your smartphone, tablet or any other external device to the sound bar to play music, pair your device to the sound bar. Select YAS-408 7E362E Bluetooth in devices list.

Samsung TV User Guide

Please read the following Safety Instructions before using your TV.

Caution: To reduce the risk of electric shock, do not remove cover or back. High voltage is present inside, it is dangerous to make any kind of contact with any internal parts of this product. There are no user serviceable parts inside. Refer all servicing to qualified personnel.

Home Screen

In Home Screen, you can easily run the apps that have been used previously or frequently. The apps can also be moved or deleted in the screen.

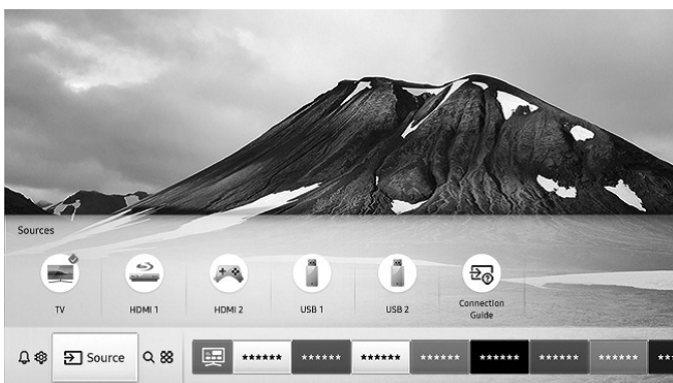

e-Manual: Get help from a detailed, on-screen user's manual built into your TV.

To Note:

- The slots and openings in the cabinet and in the back or bottom are provided for necessary ventilation. To ensure reliable operation of this apparatus and to protect it from overheating, these slots and openings must never be blocked or covered.
- Do not place this apparatus in a confined space, such as a bookcase or built-in cabinet, unless proper ventilation is provided.
- Do not place this apparatus near or over a radiator or heat register, or where it is exposed to direct sunlight.
- Do not place vessels (vases etc.) containing water on this apparatus, as this can result in a fire or electric shock.
- Do not expose this apparatus to rain or place it near water (near a bathtub, washbowl, kitchen sink, or laundry tub, in a wet basement, or near a swimming pool, etc.). If this apparatus accidentally gets wet, unplug it and contact an authorised dealer immediately.
- This apparatus uses batteries. In your community, there might be environmental regulations that require you to dispose of these batteries properly. Please contact your local authorities for disposal or recycling information.

Samsung TV User Guide cont'd

- Do not overload wall outlets, extension cords, or adaptors beyond their capacity, since this can result in fire or electric shock.
- Power-supply cords should be placed so that they are not likely to be walked on or pinched by items placed upon or against them. Pay particular attention to cords at the plug end, at all outlets, and at the point where they exit from the appliance.
- To protect this apparatus from a lightning storm, or when left unattended and unused for long periods of time, unplug it from the wall outlet and disconnect the antenna or cable system. This will prevent damage to the set due to lightning and power line surges.
- Before connecting the AC power cord to the DC adaptor outlet, make sure that the voltage designation of the DC adaptor corresponds to the local electrical supply.
- Never insert anything metallic into the open parts of this apparatus. This may cause a danger of electric shock.
- To avoid electric shock, never touch the inside of this apparatus. Only a qualified technician should open this apparatus.
- Be sure to plug in the power cord until it is firmly seated. When unplugging the power cord from a wall outlet, always pull on the power cord's plug. Never unplug it by pulling on the power cord. Do not touch the power cord with wet hands.
- If this apparatus does not operate normally - in particular, if there are any unusual sounds or smells coming from it - unplug it immediately and contact an authorised dealer or service centre.
- Be sure to pull the power plug out of the outlet if the TV is to remain unused. Accumulated dust can cause an electric shock, an electric leakage, or a fire by causing the power cord to generate sparks and heat or by causing the insulation to deteriorate.
- To turn off this apparatus completely, disconnect it from the wall outlet. To ensure you can unplug this apparatus quickly if necessary, make sure that the wall outlet and power plug are readily accessible.
- To clean this apparatus, unplug the power cord from the wall outlet and wipe the product with a soft, dry cloth. Do not use any chemicals such as wax, benzene, alcohol, thinners, insecticide, aerial fresheners, lubricants, or detergents. These chemicals can damage the appearance of the TV or erase the printing on the product.

Remote Control

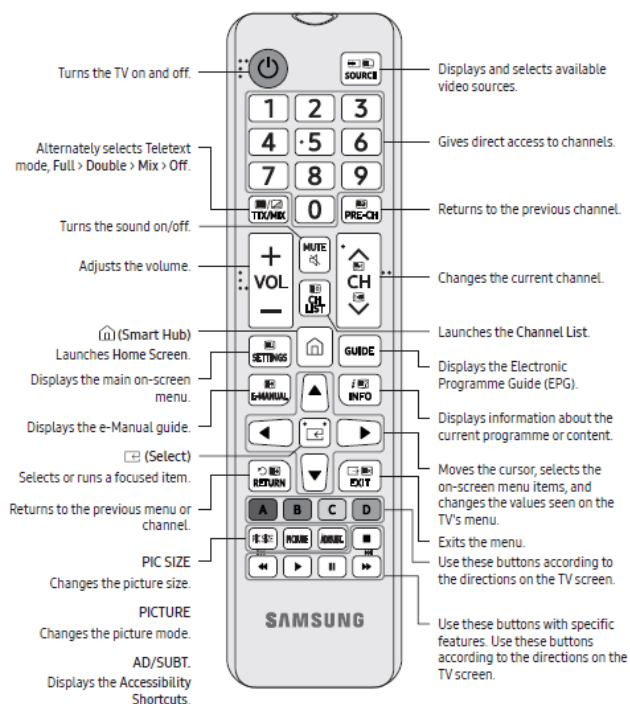

Connecting to the Internet

Connecting the TV to a network gives you access to online services such as the Smart Hub, as well as software updates.

- For more information about Smart Hub, see the e-Manual chapter, "Smart Features > Smart Hub".
- The shape of the rear panel differs among the models.

Network Connection - Wireless

Connect the TV to the Internet using a standard router or modem.



Network Connection - Wired

There are three main ways to connect your TV to your network using cable, depending on your network setup. They are illustrated starting below:



- The TV does not support network speeds less than or equal to 10Mbps.
- Use Cat7 (*STP Type) cable for the connection.
 - * Shielded Twist Pair

Controlling External Devices with the TV Remote - Using the Universal Remote

You can control external devices connected to the TV using the remote control. To control external devices, register them by following the instructions on the screen.

This function may not be supported depending on the model. You can also use the **Anynet+ (HDMI-CEC)** function to operate external Samsung devices with your TV's remote control without any additional setup.

Certain external devices connected to the TV may not support the universal remote feature.

Do not place any obstacles in front of an external device. It may cause signals from the remote control to be transmitted improperly.

The TV memorises both the external device and its connection port (HDMI 1, HDMI 2, etc.).

Connecting devices to your TV

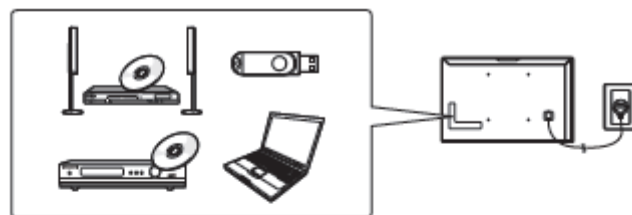

You can connect various external devices using the connectors located at the back of the product. Check the connectors and then refer to the Quick Guide for more instructions on supported external devices.

For more information about connections, see the e-Manual chapter "Connections". Make sure you have the correct cable before plugging it in. Illustrations of common plugs and ports are shown below.

	Cable Plugs	Ports	
HDMI			
USB			
Optical			

Apple TV User Guide

To get started with your Apple TV, follow these steps.



Here's what you need:

- Personal Internet*
- A TV or other display with an HDMI port
- An HDMI cable (On Apple TV 4K, you need an HDMI 2.0 or later compatible cable)

If you want to set up your Apple TV with your iOS device, do these things first on your iOS device:

- Update to the latest version of iOS.
- Sign in to iCloud with your Apple ID and turn on two-factor authentication for your Apple ID.
- Turn on iCloud Keychain in iCloud Settings.
- Turn on Bluetooth and connect to your home Wi-Fi network.*

*Apple TV doesn't support public or subscription networks with sign-in requirements.

1. Plug it in and turn on your TV

Plug your Apple TV into power and connect it to your TV with an HDMI cable. To watch films in 4K HDR on Apple TV 4K, make sure that you're using an HDMI 2.0 or later cable, and have a TV that supports 4K, HDR, or both. You can also set up your Apple TV 4K to play sound in Dolby Atmos.

Turn on your TV and select the HDMI input that your Apple TV is connected to. Don't see the set up screen?

If you don't want to connect to Wi-Fi during setup, you can connect your Apple TV to your router with an Ethernet cable.

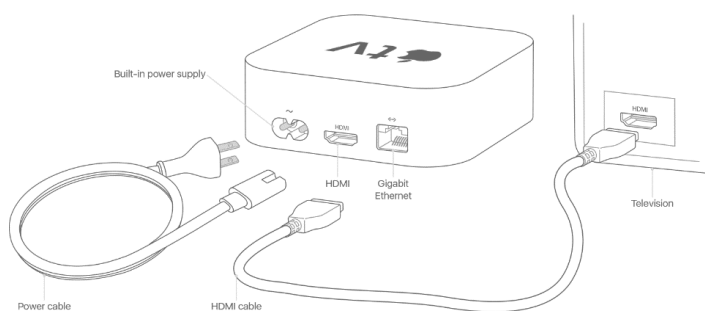

Apple TV User Guide cont'd

2. Choose your language and turn on Siri

Swipe on the Touch surface of your Apple TV Remote to find your language and country or region. To choose an option, click the Touch surface. If you choose the wrong language, press the Menu button to return to the previous screen.

If asked, choose whether to use Siri. Learn more about [using your Apple TV Remote to control your Apple TV](#).

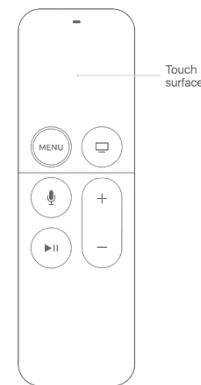

3. Continue setup with your iOS device or set up manually

To automatically add your Apple ID and Wi-Fi settings to your Apple TV, choose Set Up with Device. Then unlock your iOS device, hold it next to your Apple TV and follow the onscreen steps on your iOS device and Apple TV.

If you don't want to set up your Apple TV with your iOS device, choose Set Up Manually. Then follow the onscreen steps on your Apple TV to connect to your home Wi-Fi network and sign in with your Apple ID.

If you don't have an Apple ID, [you can create one](#).

If you forgot your Apple ID, [learn what to do](#).

4. Sign into your TV provider

In some countries and regions, you might be able to sign in to your TV or cable provider on your Apple TV to [watch TV shows and films included in your cable or TV subscription](#).

[If you receive an Apple TV from your cable provider](#), then your Apple TV should already be authorised for your subscription right out of the box.

5. Choose settings

Turn on One Home Screen to keep the Home screen and apps the same across every Apple TV. Choose a room where your Apple TV is to automatically add it to the Home app on your iOS device and Mac. And download Aerial screen savers.

Apple TV User Guide cont'd

If you have an Apple TV 4K connected to a 4K television that supports HDR or Dolby Vision, you might be prompted to run a short display test. Follow the onscreen instructions to run the test and confirm that you have a clear picture. Learn more [about 4K, HDR and Dolby Vision on your Apple TV 4K](#).

6. Get apps and start streaming

When setup is complete, you'll see the Home screen. From here, you can watch your favourite shows, films and [discover more of what you love to watch in the Apple TV app](#). You can also [download games and apps from the App Store](#).

You might also want to [check for updates on your Apple TV](#).

To learn more about your Apple TV, [read the Apple TV user guide](#).

If your Apple TV won't turn on:

Make sure that your Apple TV is plugged in to power and check the HDMI cable is securely connected to your Apple TV and television. If your Apple TV still doesn't power on, show video or play sound, [learn what to do](#).

If you can't use the remote:

You might need to charge your Apple TV Remote. If your remote is charged and isn't responding, press and hold the Menu and Volume Up buttons for two seconds.

If you purchased an Apple TV from someone and it didn't come with a remote, then you'll need to buy an Apple TV Remote to set up your Apple TV.

If you can't set up your Apple TV or see an error message:

If your Apple TV stops responding during setup, unplug your Apple TV from power, then plug it back in.

If you can't get past a screen during setup, try connecting your Apple TV to a different Wi-Fi network, like a personal hotspot from your phone. After setup is complete, go to Settings on your Apple TV and connect to your home Wi-Fi network.